

Guidelines for Meter Installations

D I V E R S I O N S M A N A G E M E N T



Tim Donovan
Updated January 2011

Table of Contents

Glossary	3
Introduction.....	4
Customer Notification.....	4
Initial Site Assessment.....	5
Selecting a water meter.....	5
5.1 Meter installation types.....	6
Meter Installation.....	7
6.1 Materials supplied by the contractor.....	7
6.2 Certification requirement.....	7
6.3 General installation specification.....	7
6.4 Weldings.....	8
6.5 Pre-commissioning.....	8
6.6 Anti-tamper seals and devices.....	8
6.7 Access to meters.....	9
6.8.1 Sample Meter Installation Plans.....	9
6.8.1 MIP-1: Exposed delivery pipe.....	9
6.8.2 MIP-2 Underground main brought to the surface.....	9
6.8.3 MIP-3 : Exposed delivery pipe lying flat on the surface.....	10
6.8.4 MIP-4 : Exposed suction pipe located on (or above) an embankment.....	10
6.8.5 Buried meters (depth < 1.5m).....	10
6.9 Specification – Installation of Mechanical and Nonmechanical Meters.....	11
6.9.1 General.....	11
6.9.2 Scope.....	11
6.9.3 Primary element installation.....	11
6.9.4 Cabling and conduits.....	11
6.9.5 Integrally located ancillary equipment.....	12
6.9.6 Power supply and electrical connections.....	12
6.9.7 Configuration and testing.....	12
6.10 Specification: Below Ground Meter Installations.....	13
6.10.1 Introduction.....	13
6.10.2 Buried meters.....	13
6.10.3 Meter Boxes.....	14
7. Practical Completion.....	14
7.1 General.....	14
7.2 - Procedure: Meter Installation Checklist and Meter Location Photos.....	14
7.2.1 Completion of meter installations.....	14
7.2.2 Information to be provided by the contractor.....	15
8. Service and Repairs of Meters.....	16
9. Further Information.....	16
10. Document Review.....	16
11. Appendix A – Sample Meter Installation Checklist.....	17
12. Appendix B – Meter Installation Plans.....	18
12.1 MIP-1 Exposed delivery pipe.....	18
12.2 MIP-2 Underground main brought to the surface.....	18
12.2 MIP-2 Underground main brought to the surface.....	19
12.3 MIP-3 : Exposed delivery pipe lying flat on the surface.....	20
12.4 MIP-4 : Exposed suction pipe located on (or above) an embankment.....	21

Glossary

Contractor	<p>Any contractor (or subcontractor) employed by Melbourne Water to undertake work to Melbourne Water's specifications for any of the following purposes:</p> <ul style="list-style-type: none">• Site assessments,• Installing the water meter, ancillary equipment and associated pipework, to Elster's specifications,• Reading and recording the display from the water meter,• Maintaining the condition of the installed water meter.
Data storage unit	<p>An electronic device (such as a data logger) whether integral or external to the meter used to store flow data.</p>
Data logger	<p>A device, integral or remote from the meter, used to store data over specified periods, and with the capability to download data.</p>
Elster Metering	<p>Meter supplier for the majority of Melbourne Water's diversion customers.</p>
Flow display unit	<p>A part of the meter that displays the measurement results whether integral or external to the meter.</p>
Licence Holder	<p>Holder of a water allocation, interim water allocation or water licence.</p>
Meter	<p>A device for measuring, or giving an output signal proportional to, quantities of water passed and/or the rate of flow in a pipe or channel</p>

Introduction

The diversions metering program is for the installation of meters on active irrigation / commercial licence holders within the Yarra Basin greater than 5ML. To date over 700 meters have been installed.

The installation of meters is considered necessary for the future management of our water resources and provides Melbourne Water with a greater knowledge and control of water use whilst providing licence holders the flexibility to manage their allocated volumes without other limiting factors being applied. (eg. Currently the licence area component restricts diverters in their ability to irrigate)

The benefits of installing meter on diversion licences are:

1. More effectively manage Melbourne Water's unregulated diversions function;
2. Provide an accurate record of volumes diverted;
3. Allow irrigators who manage their water efficiently to make optimum use of their water entitlement;
4. Provide efficient flexible management of the river system during low flow roster / restriction conditions;
5. Enforce diversion rates during low flow roster / restriction periods;
6. Monitor actual usage to ensure it falls within individual licensed allocated volumes;
7. Further facilitate the development of a Water Trading Market by allowing the efficient Transfer of Water Entitlements; and
8. Provide water use data for Stream Flow Management Plan (SFMP) development
9. Protect the rights of other water users including Melbourne Water's urban harvesting capability and the environment

Customer Notification

Melbourne Water will write or verbally contact customers that will require a meter. Notification will explain the benefits of metering (see above), timing of the installation and also details on our contractor who will be undertaking the works.

A checklist with each customers address and contact details will be provided to the Contractor (see Appendix A).

Initial Site Assessment

There is a need to undertake an assessment of existing irrigation works in order to gather certain information before an informed choice can be made regarding the water meter to be installed. The information relates to the size, type of pipe and general pumping plant set-up. This assessment determines the most suitable type of meter for the majority of situations as well as enabling the calculation of the likely range of flow rates to be metered and discussion with the licence holder on preferred location. This is information that must be known before a meter choice can be made.

Not all of the metered entitlements will be required to have a meter installed. Those entitlements with no works (sleepers) or decommissioned works (dozers) will not need a meter until the entitlement holder decides to install or recommission works. This will need to be noted on the Meter Installation Checklist (Appendix A)

Selecting a water meter

All irrigation meters installed must conform to the following criteria :

- 4 The meter must be an irrigation type meter supplied from a manufacturer compliant with Australian Standard/New Zealand Standard (AS/NZS) 9001 (Quality management systems).
- 4 The meter must have a permanent and unique identifying number.
- 4 Where the meter is an in-line type and is connected using flanges, then these flanges shall meet the requirements of AS 2129 (Flanges for pipes, valves and fittings).
- 4 The meter register unit and meter body must be able to be sealed with security devices consistent with Clause 2.6 of AS 3565.1 - 1998.
- 4 Be installed in a straight pipe length 10 times the pipe diameter upstream of the meter and 5 times the pipe diameter downstream of the meter.
- 4 Have an electronic output (pulse or analogue) and be compatible with a datalogger capable of recording extraction rate and volume
- 4 Meter flow accuracy is to be NATA certified to +- 2%.
- 4 If the meter relies in any way on an electrical power source, then it shall have a non-volatile memory to ensure that recorded data is not lost in the event of a power or battery failure. In this instance, the meter must also have the capacity to record the time, date and duration of any power failures as well as the nature of the fault. Data must be able to be retrieved at all times.
- 4 If the meter relies on a mains power source it must be hard wired to ensure that the power source cannot be deliberately interrupted.

5.1 *Meter installation types*

Site assessments will determine the most suitable type of meter and installation for the conditions. Meters will be selected according to their compatibility with installation types and operating conditions.

The following factors should be considered in determining the most suitable meter type :

- Meters suitable to the chosen installation type
- Water quality (presence of weeds and minerals)
- Flow velocity (minimum and maximum as per Elster's specifications)
- Meter size range (sizes suitable for existing pipework and expected flow velocities)
- Operating pressures
- Power requirements
- Pipe types.

There are two categories of meter available – mechanical and non-mechanical. Each has its advantages and disadvantages when used in different operating conditions. For example, mechanical meters are generally suited to clean water, while non-mechanical meters generally cope better with debris. In addition, mechanical meters are generally inexpensive to purchase but may require more maintenance, while non-mechanical meters are more expensive, but are generally less prone to wear and tear. Mechanical meters include propeller actuated (PA), paddlewheel and turbine meters. Non-mechanical meters include ultrasonic and electromagnetic meters.

The types of water meters that are used by Melbourne Water include :

- Mechanical

These meters consist of an impeller (a propeller driven by the water flow), paddle or turbine mounted in the run of the pipe and mechanically connected via couplings and gears to an output device (analogue dial or electronic display). Water flow turns the impeller or paddle, causing gear wheels to rotate the dial or output device. The output device indicates the flow rate and/or cumulative flow. This is the most common type of meter.

- Electromagnetic

These meters operate by creating a magnetic field across the water flow, which acts as an electrical conductor, inducing an electrical voltage. The voltage, measured by electrodes in the meter body is proportional to the mean velocity of the water. The mean velocity is converted to the flow rate. The display modules on electromagnetic meters show flow rates and cumulative volumes and can be remotely mounted, making the meter suitable for underground installation.

Meter Installation

6.1 *Materials supplied by the contractor*

The contractor must supply the following materials to undertake meter installations :

- Suitable vehicles
- GPS unit
- Digital cameras
- Personal protection equipment (PPE)
- Tape measures
- Whiteboards and marker pens
- Marker posts where require (steel pickets)

6.2 *Certification requirement*

Prior to commencing any meter installation and/or maintenance activities, the contractor must undertake training in the installation and maintenance of meters, as provided by the meter manufacturer Elster Metering.

Manufacturer certification ensures that the contractor will install and maintain the meter to the manufacturer's standards, to meet the required accuracy range of $\pm 2\%$.

Manufacturer certification applies to all individual personnel employed by a contractor to install and/or maintain meters on behalf of Melbourne Water.

6.3 *General installation specification*

- The pipe in which the meter is installed must be straight with uniform cross section and without any fittings for at least 10 pipe diameters upstream of the meter and 2 diameters downstream of the meter.
- A meter shall be installed such that it and the required straight length of pipe specified above are completely filled with water under all operating conditions.
- The expected operating flow velocity range must be within the limits provided by Elster Metering.
- Meters that measure one directional flow shall be installed with the arrow pointing in the direction of flow.
- Meters and associated pipework shall be installed and tested to ensure that the system is free of any water leaks and that the meter is operating correctly.
- Adequate support is required beneath the meter to prevent movement of meter and pipes.
- The meter and required straight lengths of pipe specified above must be installed such that rotation of flow or turbulence caused by the pump, elbows or changes in pipe diameter will not affect the accuracy of the meter.
- In situations where it is considered that a greater than normal presence of suspended solids in the water may affect meter accuracy consideration should be given to the installation of a filter/strainer device that can be easily

maintained and located outside the required straight lengths of pipe specified above. Please discuss with Melbourne Water if this may be the case.

- Where a meter is installed below ground, sufficient space shall be provided to facilitate easy access for maintenance and reading.
- All extraction points are to be metered as close as practical to the point of extraction.
- All meters shall be located where possible on the discharge side of the pump.
- Where it is possible for air (eg wind) to cause the meter to register when the pump is not operating, the pipe-work must be fitted with a flap valve or some other permanent mechanism to prevent this occurring.
- Where meter is to be installed on a portable pump, the meter is to be fixed in position along with appropriate straight lengths of pipe at the authorised diversion location. Diversion customer are to connect to this fixed diversion point with their pumping equipment.

6.4 Weldings

- Field treatment or patch painting of all welds and cuts to pipework must be carried out with an appropriate corrosion protection product.
- All welding shall be carried out in a manner that ensures compliance with the relevant Australian Standard.

6.5 Pre-commissioning

A pre-commissioning check shall be carried out for all meters installed, is to be in accordance with the manufacturer's recommendations and should include:

- Ensure all flange bolts and/or body cover bolts are fully tightened.
- Check that the meter has been installed in the correct manner as defined by the manufacturer's requirements.
- Slowly open the supply to flush all air entrapped in the pipework, whilst taking care not to exceed the meter's maximum rated operating conditions.
- Once certain that the meter has been cleared of any entrapped air and is installed in the manner recommended by the manufacturer, install all anti-tamper seals and devices.

6.6 Anti-tamper seals and devices

- Water meters shall include anti-tamper seals and devices that prevent and/or indicate tampering of the meter, its adjustment device and correction device.
- Anti-tamper seals and devices must protect access to all parts of the meter that may affect the interpretation of flow volumes and rates.

Note that all external sealing will be undertaken with high tensile stainless steel wire and prescribed nickel plated copper ferrules.

6.7 Access to meters

- The meter installation site must be accessible to vehicles and machinery wherever practical.
- The meter should be installed above ground wherever possible and free from other obstructions.
- Safe access must be provided to meters (e.g. provision of covers, steps, platforms and handrails etc). All access provisions for meters installed on riverbanks shall comply with the requirements of relevant Health and Safety Acts and be in accordance with relevant Australian Standards.

6.8.1 Sample Meter Installation Plans

Appendix B contains various Meter Installation Plans (MIPs) for the five types of meter installations. These include the following installations drawings that would be commonly used :

1. MIP for exposed delivery pipe – Plan no: MIP-1
2. MIP for underground main brought to the surface – Plan no: MIP-2
3. MIP for exposed main lying on the surface for sizes 25-50mm in diameter Plan no: MIP-3

The following plans are for those installations that are not commonly used by Melbourne Water :

4. MIP for buried meters (depth < 1.5m) – Plan no: MIP-4
5. MIP for exposed suction pipe located on (or above) an embankment – plan no: MIP-5

Please contact Melbourne Water first if these uncommon meter installations may be a possibility.

6.8.1 MIP-1: Exposed delivery pipe

This is the preferred meter installation type for surface water installation. Any new or proposed irrigation system should allow for a meter to be installed in this manner.

The location of valves as specified on the plan is important, as is the requirement of 10 times the diameter of the pipe before the meter and 5 times the diameter of the pipe after the meter. A concrete slab or other support is required under the meter for support, weed reduction and ease of maintenance.

6.8.2 MIP-2 Underground main brought to the surface

This option is to be used when the meter is of a mechanical type that cannot be buried or when burial is not considered (for all meter types). This option can also be used with mechanical type meters that require an increase in pipe size to comply with the velocity requirements of the meter. A concrete slab is required under the meter for weed reduction and ease of maintenance.

This type of installation is potentially expensive in that there are a number of bends and additional flanges to accommodate valves and thrust blocks.

Melbourne Water prefers all meter installations to be above ground for ease of reading and maintenance. All isolation and non-return valves must be placed downstream of the meter.

6.8.3 MIP-3 : Exposed delivery pipe lying flat on the surface

This installation applies to small diameter delivery lines with meters located on the surface of the ground. The meter and delivery must be stabilised with a concrete slab or other support recessed into the ground. An animal protection cover or a marker pit may afford additional protection of the meter if needed. The location of the meter should be clearly identified by a guidepost or marker to avoid accidental damage.

6.8.4 MIP-4 : Exposed suction pipe located on (or above) an embankment

This type of installation should only be considered if the pipe is located in a stable situation (such as when protected by bank and bed sands) and if it is not possible to install on the delivery side of the pump. This type of installation should not be considered if the pump installation has experienced loss of the suction pipe and foot valve in flooding situations in the past.

An access platform will be required if the suction is located down or 'out from' an embankment. Access to the meter by rope or sliding down the suction pipe is NOT acceptable. The access platform will comply with workplace health and safety standards (this may involve steps, ladders, rails etc depending on the situation). An installation involving a substantial access platform is likely to be expensive and is regarded as potentially impractical.

Therefore, this type of installation is discouraged if more cost effective alternatives are available (e.g. locating the meter on less flood prone land).

6.8.5 Buried meters (depth < 1.5m)

This installation is only to be used for burial depths up to 1.5m and will only be acceptable for non-mechanical type meters with remote flow displays. This is a rare scenario.

Mechanical type meters are NOT to be buried under any circumstance. All buried meters are to be installed with wrapping protection in accordance with the specification.

For burial depths to the meter of greater than 1.5m, an inspection well may be required. Please discuss first with Melbourne Water.

6.9 Specification – Installation of Mechanical and Nonmechanical Meters

6.9.1 General

All contractors that carry out the installation of mechanical meters should have completed training by the Elster Metering to ensure that the meter has been competently installed.

6.9.2 Scope

Meter installations shall include, but not be limited to the following: -

- Provision of a safe working environment (including training of personnel, lifting, monitoring and other equipment etc)
- Installation of the primary element and associated pipework into the pipeline. Includes provision of tamper proof provisions and any fittings (including valves, straighteners) required.
- Installation of cabling to connect the primary element to the flow display unit (where separate to the meter). Where the flow display unit is remote from the primary element, the cabling is to be installed in conduit.
- Where flow display unit and data storage unit are external to the meter, the flow display unit and data storage unit shall be installed in a meter box. Installation shall include the connection of required cabling.
- Installation and connection of power supply (where applicable).

6.9.3 Primary element installation

- The primary element must be located in straight clean pipe of uniform, circular cross section and without any fittings or obstructions for a minimum distance of 10 pipe diameters upstream and 2 pipe diameters downstream of the metering point.
- The primary element is to be orientated so that the arrow indicating flow direction on the body of the primary element is pointing in the same direction as the normal flow in the pipeline.
- Where it is likely that air may become entrapped near the meter it is required that an air valve be installed.
- Unless noted otherwise, the contractor is to supply all items necessary to install the meter including nuts, bolts and gaskets as necessary to make all flanged connections.
- All flanged pieces shall be flanged to Class 14, AS 4087. Note Australian Standard AS 4087 requires boltholes on flanges to be equally spaced either side of top centre of pipe. Flange bolts shall be galvanised.

6.9.4 Cabling and conduits

All cabling joining the primary element to the flow display unit and other ancillary equipment shall be installed in conduit. Inside pits and inspection wells the cabling is

to be installed in flexible conduit whilst outside these areas, the cabling is to be installed in rigid PVC conduit. The size of the conduit should allow all necessary cabling and plugs (or connectors) to be pulled through easily. All buried conduit is to be buried to a depth of 600mm below natural surface and utilise long radius bends when entering or exiting. Cabling longer than 20m may require the installation of a booster to the output signal and a suitable enclosure should be provided.

6.9.5 Integrally located ancillary equipment

This section applies to other ancillary equipment that are integral to the meter.

Remote located ancillary equipment (meter box)

This section applies where the flow display unit and/or other ancillary equipment are to be located remote from the meter.

The flow display unit and data storage unit (where separate) shall be installed in a ventilated and insulated meter box fixed to the mounting pole at a nominal height of 1.8m above natural surface or above flood height or as agreed by Melbourne Water. The installation of the meter box shall include all electrical and cable connections to the flow display unit and data storage unit (where separate). The contractor shall supply the mounting pole and all brackets and fittings necessary for fixing the meter box to the mounting pole.

6.9.6 Power supply and electrical connections

This section applies where the ancillary equipment (eg. flow display unit) are require electrical power.

Mains powered

All electrical connections are to be carried out by a qualified electrical contractor.

Rechargeable battery connected to other power source

All electrical connections are to be carried out by a qualified electrical contractor.

Non-rechargeable battery

The battery should be positioned to allow for easy maintenance.

6.9.7 Configuration and testing

Configuration and testing of the meter shall be undertaken in accordance with Section 7 – Procedure: Configuration and Testing.

6.10 Specification: Below Ground Meter Installations

6.10.1 Introduction

The preferred location for all meters is above ground. However, installations that may require a meter located below ground include:

- Shallow installations (depths less than 0.6m) - where the cost of relocating pipework above ground and protecting the meter favours burial and protection of the meter using a wrapping system or a meter box.
- Moderate installations (depths 0.6m to 1.5m) - where the cost of relocating pipework above ground and protecting the meter favours the installation of an access pit. Please discuss with Melbourne Water first.
- Deep installations (depths greater than 1.5m) – where the cost of relocating very large diameter pipework above ground favours the installation of an inspection well. Please discuss with Melbourne Water first.

Where conditions necessitate installing a meter below ground, the meter location must be clearly identified. All meters located below ground must be adequately protected from corrosion and other effects of contact with soil and moisture.

6.10.2 Buried meters

Where buried meters are located down to 0.6 m below the surface they are to be wrapped with Denso Wrap or similar four-pack wrapping medium to ensure the meter and ancillary components are adequately protected from corrosion and other effects of contact with soil and moisture. Only low maintenance meters (i.e. some non-mechanical meters) with clearly marked meter locations can be used in buried applications.

Note: burial of meters is generally not recommended - buried meters are difficult to access and potentially very difficult to locate, should removal or visual inspection be required.

Marker systems for buried meters will comprise one of the following:

- A capped inspection shaft located directly above the meter and a marker pole within 1 m of the shaft, or
- Marker pole located within 0.5m horizontally of the meter itself giving the depth to the meter and which side of the pole the meter is located, and
- A strip of marker tape, placed below ground, at least 0.30m above the meter itself, to indicate the position of the meter during excavation activities.

6.10.3 Meter Boxes

Where meters are located down to 0.6 m below the surface, a meter box may be used to house the meter. Meter boxes must:

- Be constructed of stable material suitable for contact with soil, moisture and exposure to the elements
- Have a cover and adequate internal drainage
- If protruding above the surface of the ground, the ground must be contoured to the top of the meter box to protect the box and provide drainage.

Commercially available meter boxes may be used or alternatively, meter boxes may be fabricated from the following materials:

- Concrete
- Black brute pipe
- Other approved materials

Meters box locations must be indicated by a marker pole adjacent to the meter box.

7. Practical Completion

7.1 General

All meter installations shall be configured and tested in accordance with this section as soon as practicable upon completion of each installation. It is a requirement that all meter installations undergo configuration and testing to ensure that they meet the requirements of the specification.

However, it is recognised that the ability to perform configuration and testing is dependent on the availability of water at each site. At sites where water is available, full configuration and testing of the meter installation is to be carried out at the time of installation. At sites where water is not available, minimum testing is to be carried out with full testing and configuration and/or calibration of the meter installation to be carried out later at the time of first flow.

7.2 - Procedure: Meter Installation Checklist and Meter Location Photos

7.2.1 Completion of meter installations

Melbourne Water has already provided the contractor with Meter Installation Checklist (see Appendix A) for each meter installation site.

The Meter Installation Checklist must be signed by the entitlement holder and the Melbourne Water contractor on completion of each meter installation.

7.2.2 Information to be provided by the contractor

For every completed installation, the contractor must provide Melbourne Water with the following:

- A signed Meter Installation Checklist
- Meter Location Photos
- Meter details (model, size, serial number etc)
- GPS coordinates of the location of the meter within the pipework (coordinates must be recorded as Easting and Northing, to GDA 94 format)
- Initial meter reading
- Name of the person who installed the meter
- Dimensions to fixtures both upstream and downstream of the installed meter
- Site access requirements (e.g. hard to access by vehicle)

Each completed Meter Installation Checklist is to be signed by the contractor stating that the meter has been installed to the manufacturer's standards in a manner that enables the meter to operate within the accuracy specified.

Meter Location Photos

For every completed meter installation the contractor must take a minimum of two Meter Location Photos (MLPs) showing:

- The meter installed within the pipework, and
- The meter location in relation to the meter box (This will be a rare situation. Need to discuss with Melbourne Water first)

All MLPs must:

- Show the works and meter side-on (i.e. the meter and 10 – 2 spacings must be clearly visible, as documented and measured in Meter Installation Checklist)
- Show a white board with the entitlement holder's name, meter number and date of installation (details on white board must be clearly visible)
- Be digital images (*JPEG* format, resolution 640 x 320 or similar)
- Be labelled with a filename (filename must include photo number and meter number. Eg 4658180001_Meter No 03PFF00730_1.jpg)

Notes:

- Buried meters must be photographed before the meter is covered.
- Multiple or panoramic photos are acceptable for large installations, provided the images are numbered in sequence.
- White boards should be legible.

8. Service and Repairs of Meters

Maintenance shall be performed in accordance with the Elster Metering's specifications, and shall be undertaken by a manufacturer certified contractor. Generally meters should be serviced after five years of operation.

Maintenance may include, but is not limited to:

- Corrective maintenance (replacement/repair of non functioning parts) and preventative maintenance (replacement of worn parts which are still functioning but expected to fail in the short term)
- Removal of the meter from the property for repair, replacement, testing and configuration or any other reason.
- Excavation of works to locate/service a meter
- Relocation of a meter and associated works
- Installation of a meter associated with new works (only upon approval of Melbourne Water)
- Cleaning/clearing of a meter affected by iron bacteria, siltation or other contamination (except when done as part of a condition inspection)
- Removal/replacement of anti-tampering devices
- Replacement/repair of electronic readouts, data loggers, electrodes, transducers, cabling, batteries and solar panels

9. Further Information

Additional information can be obtained from Melbourne Water's Diversions Management team at 131 722.

10. Document Review

This document is due to be reviewed by December 2011.

12. Appendix B – Meter Installation Plans

12.1 MIP-1 Exposed delivery pipe

Meter Installation Plan for Exposed Main Lying on the Surface

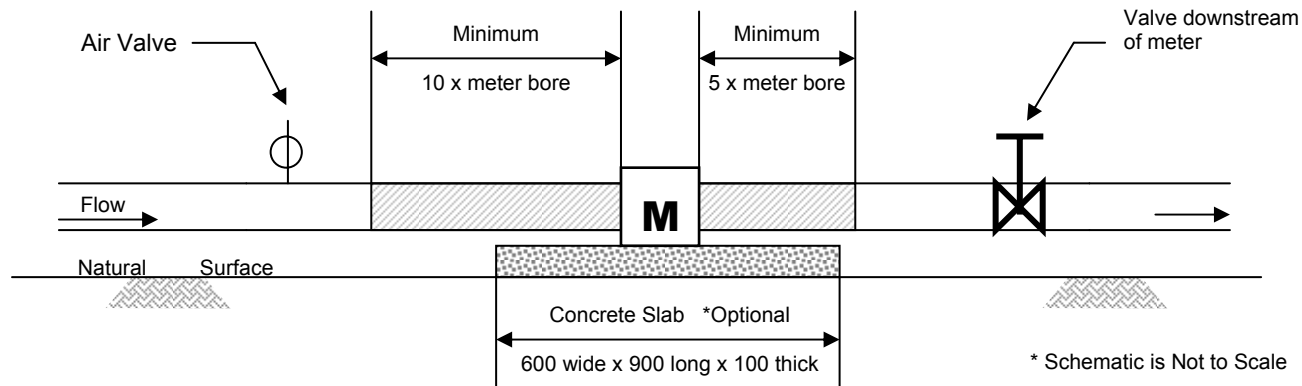

Notes:

- Dimensions
 - Millimetres unless otherwise stated
- Tamper Proofing
 - to be provided in accordance with specifications
- Base
 - Concrete Slab or equivalent – to be located centrally underneath the meter
- Non Return Valves
 - It is recommended that the non return valve be placed downstream of the meter, however, if they are, they must only be those that open FULLY and hinge at the top. Centre hinge or butterfly valves should be installed upstream of the meter
- Lightning Protection
 - Lightning protection to be provided in accordance with manufacturers specifications
- General
 - Cabling from meter to ancillary equipment (data logger, flow display) and or to power supply omitted for clarity

LEGEND

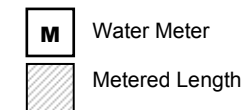

Meter Size	Pipe length before meter	Pipe length after meter
50mm	500mm	250mm
80mm	800mm	400mm
100mm	1000mm	500mm
150mm	1500mm	750mm
200mm	2000mm	1000mm

12.2 MIP-2 Underground main brought to the surface

Meter Installation Plan for Underground Main brought to the surface

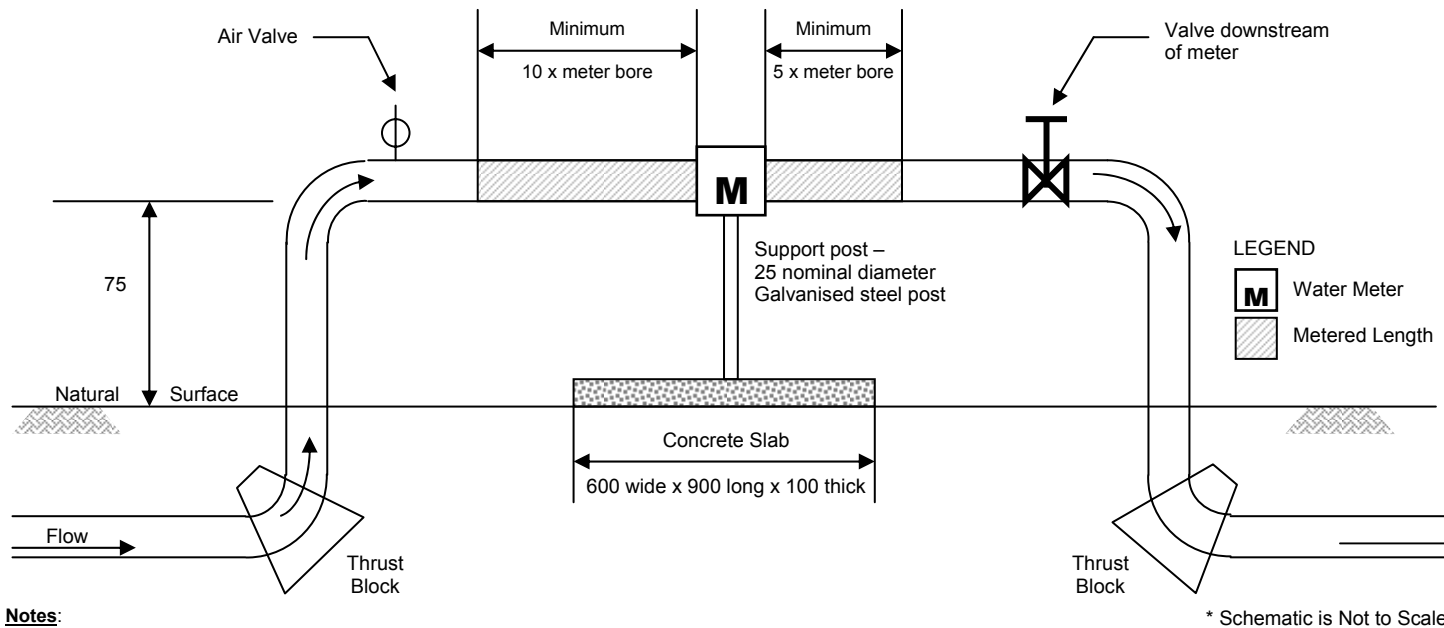

Notes:

- Dimensions
- Millimetres unless otherwise stated
- Tamper Proofing
- to be provided in accordance with specifications
- Base
- Concrete Slab or equivalent – to be located centrally underneath the meter
- Non Return Valves
- It is recommended that the non return valve be placed downstream of the meter, however, if they are, they must only be those that open FULLY and hinge at the top.
Centre hinge or butterfly valves should be installed upstream of the meter
- Lightning Protection
- Lightning protection to be provided in accordance with manufacturers specifications
- General
- Cabling from meter to ancillary equipment (data logger, flow display) and or to power supply omitted for clarity

Meter Size	Pipe length before meter	Pipe length after meter
50mm	500mm	250mm
80mm	800mm	400mm
100mm	1000mm	500mm
150mm	1500mm	750mm
200mm	2000mm	1000mm

12.3 MIP-3 : Exposed delivery pipe lying flat on the surface

Meter Installation Plan for Exposed Main Lying on the Surface

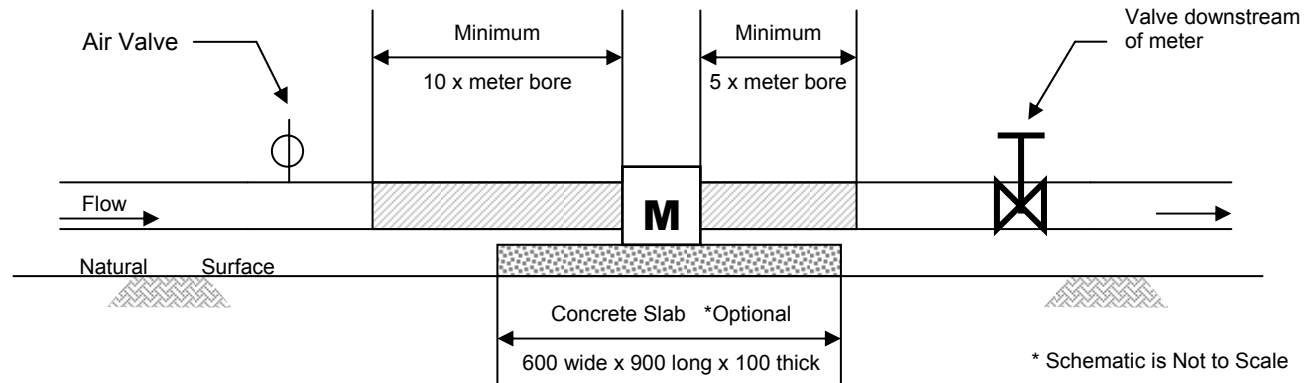

Notes:

- Dimensions
- Millimetres unless otherwise stated
- Tamper Proofing
- to be provided in accordance with specifications
- Base
- Concrete Slab or equivalent – to be located centrally underneath the meter
- Non Return Valves
- It is recommended that the non return valve be placed downstream of the meter, however, if they are, they must only be those that open FULLY and hinge at the top. Centre hinge or butterfly valves should be installed upstream of the meter
- Lightning Protection
- Lightning protection to be provided in accordance with manufacturers specifications
- General
- Cabling from meter to ancillary equipment (data logger, flow display) and or to power supply omitted for clarity

LEGEND

M	Water Meter
	Metered Length

Meter Size	Pipe length before meter	Pipe length after meter
50mm	- 500mm	- 250mm
80mm	- 800mm	- 400mm
100mm	- 1000mm	- 500mm
150mm	- 1500mm	- 750mm
200mm	- 2000mm	- 1000mm

12.4 MIP-4 : Exposed suction pipe located on (or above) an embankment

Meter Installation Plan for Exposed Suction Pipe from a Dam

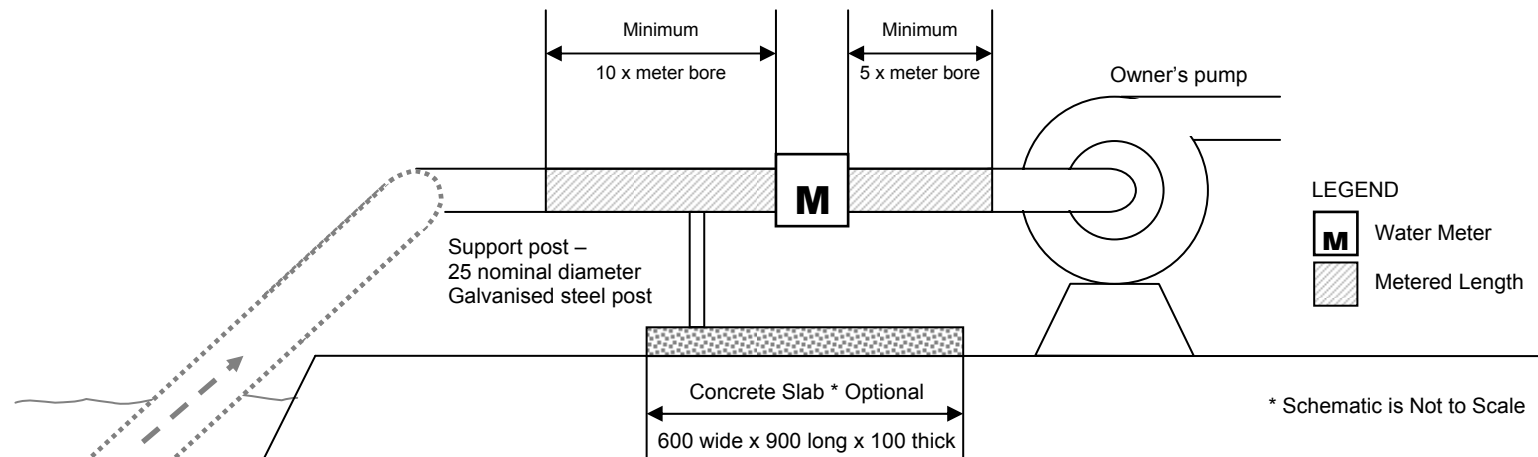

Notes:

- Dimensions
- Millimetres unless otherwise stated
- Tamper Proofing
- to be provided in accordance with specifications
- Base
- Concrete Slab or equivalent – to be located centrally underneath the meter
- Non Return Valves
- It is recommended that the non return valve be placed downstream of the meter, however, if they are, they must only be those that open FULLY and hinge at the top. Centre hinge or butterfly valves should be installed upstream of the meter
- Lightning Protection
- Lightning protection to be provided in accordance with manufacturers specifications
- General
- Cabling from meter to ancillary equipment (data logger, flow display) and or to power supply omitted for clarity

Meter Size	Pipe length before meter	Pipe length after meter
50mm	- 500mm	- 250mm
80mm	- 800mm	- 400mm
100mm	- 1000mm	- 500mm
150mm	- 1500mm	- 750mm
200mm	- 2000mm	- 1000mm